

# Airbus Guidance and Control Selected 2005 Papers

Pascal Traverse



**AIRBU**

# Airbus Guidance and control – 2005 selected papers

- ✓ Papers on
  - ✓ System
  - ✓ Control laws
  - ✓ Flight mechanics
  
- ✓ Title of the paper is on top, reference at the bottom of the page

# Airbus Guidance and control – A380 update

**FIRST FLIGHT**

**April, 27**

**AUTO LAND**

**June, 1**

**EHA LAND**

**August, 27**



# A380 Flight controls overview

- ✓ Aircraft configuration and control surfaces
  - ✓ Actuator technology
  - ✓ Power sources for Flight Controls
  - ✓ Flight Control Architecture and Computers
  - ✓ Back-up controls
  - ✓ Flight Control Laws
- 
- A black and white photograph of an Airbus A380 aircraft in flight, viewed from a low angle, flying over a body of water with white-capped waves. The aircraft is the central focus, with its four engines and high-wing configuration clearly visible.

Reference: by Xavier LE TRON, Royal Aeronautical Society “A380 Avionics/System Conference”, in London, October 2005.

# A process toward total dependability: Airbus Fly-by-Wire paradigm

- ✓ Airbus FBW safety and availability principles
- ✓ Emphasis on their evolution and on future challenges
- ✓ Physical faults
- ✓ Design and manufacturing errors
- ✓ Particular risks
- ✓ Human factor

Reference: by Pascal TRAVERSE, Isabelle LACAZE and Jean SOUYRIS, 5<sup>th</sup> European Dependable Computing Conference (EDCC-5), in Budapest, April, 2005; and Ankara Aerospace Conference, August 2005.

# NON LINEAR ROBUST AUTOLAND

- ✓ 'Robust-Multi-Inversion' technique for feedback linearization
- ✓ Application to inner and outer loop
- ✓ Simulation results

Reference: by Fabien LAVERGNE, Fabrice VILLAUME, Matthieu JEANNEAU, Sophie TARBOURIECH, Germain GARCIA, AIAA Guidance Navigation and Guidance conference, in San Francisco, August 2005.

# AWIATOR'S DESIGN OF MULTI-OBJECTIVES CONTROL LAWS

✓ Considers various criteria in the design

✓ Handling Qualities

✓ Stability margins

✓ Robustness to mass-cases

✓ Loads

✓ Comfort ...

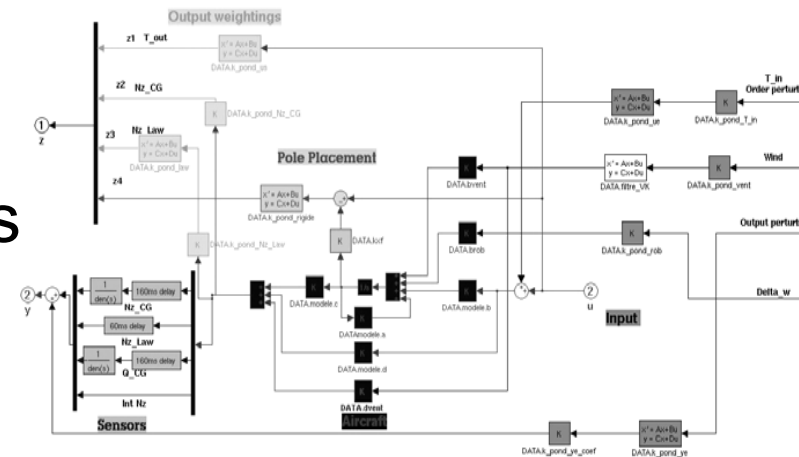

✓ Benefits

✓ In the design process: less iterations with loads

✓ In the performances: conservatism is reduced

Reference: by Matthieu Jeanneau, Jérôme Lamolie, Guilhem Puyou, Nicky Aversa. 16th IFAC World Congress. Prague, July 2005. Awarded an Honourable Mention as one of the 5 finalists for the Young Author Prize.

# FEASIBILITY OF H INFINITY DESIGN SPECIFICATIONS: AN INTERPOLATION METHOD

- ✓ Design of a controller compliant to specifications – free order
- ✓ Nevanlinna Pick interpolation method to compute lower & upper bounds of  $J^*$
- ✓ Application to multiobjective control of flexible aircraft

Reference: by Gilles Ferreres, Guilhem Puyou. In Proceedings of the American Control Conference, Portland 2005 and International Journal of Control, Vol 78, N° 12, pp.927-936, August 2005.

# HANDLING QUALITIES OF THE BAGDAD EVENT

- ✓ Flight mechanics of an aircraft
- ✓ Underline capacity of a crew to land an aircraft without flight controls available, using engine only controls
- ✓ Underline the part of luck and the feat of the crew
- ✓ Demonstrate the difficulty of doing such a flight



Reference: by Benoit LEMAIGNAN, AIAA Atmospheric Flight conference, in San Francisco, August 2005.

*Ce document et son contenu sont la propriété d'AIRBUS FRANCE S.A.S. Aucun droit de propriété intellectuelle n'est accordé par la communication du présent document ou son contenu. Ce document ne doit pas être reproduit ou communiqué à un tiers sans l'autorisation expresse et écrite d'AIRBUS FRANCE S.A.S. Ce document et son contenu ne doivent pas être utilisés à d'autres fins que celles qui sont autorisées.*

*Les déclarations faites dans ce document ne constituent pas une offre commerciale. Elles sont basées sur les postulats indiqués et sont exprimées de bonne foi. Si les motifs de ces déclarations n'étaient pas démontrés, AIRBUS FRANCE S.A.S serait prêt à en expliquer les fondements.*



**AIRBUS**

**AN EADS JOINT COMPANY  
WITH BAE SYSTEMS**